

Extreme Series | Surface Mount

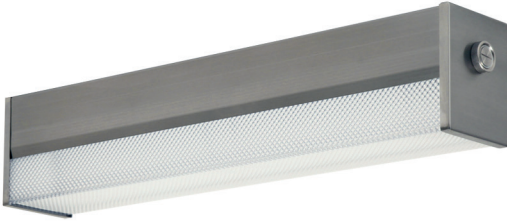

Food Processing:



Hazardous Location:



APPLICATIONS:

- ETL/cETL Listed Wet Location
- ETL/cETL Hazardous Location (Class I, Division 2; Groups A,B,C & D Class II, Division 2; Groups F & G)
- NSF Certified Food Processing (Splash Zone, Food Zone)
- Industrial & Commercial
- Transit

FEATURES:

- Tested to LM79, LM80
- L70 is >60,000 hours
- Square version available
- Available in Stainless Steel construction
- Premium Driver with Dimming standard
- Every luminaire tested to assure customer satisfaction
- 5-Year limited warranty

SPECIFICATIONS

HOUSING:

Constructed of 20GA (0.036 inch) zinc coated steel for unmatched corrosion protection. Featuring a double channel, one welded inside the other, with space between the channel sides to capture the diffuser. Threaded hubs are continuously welded into the channel ends providing a sealed wireway access. Removable plugs seal the hubs when not utilized.

Food Zone: All external metal components of stainless steel (S4 Finish Standard).

OPTIONAL PREMIUM MATERIALS:

S4 - All metal components of 304 stainless steel.

FINISH:

Painted surfaces are two mil white polyester enamel, custom colors available.

LENS:

0.125 inch StarFrost® Acrylic with 50% DR content for durability, smooth side out. See ordering information for other high quality acrylic and polycarbonate lens options. A two piece lens with center joiner band is available.

END CAPS:

Die formed of 18GA (0.048 inch) stainless steel. A threaded, knurled ring secures the end cap to the luminaire housing. End caps secure lens.

GASKETING:

EPDM is used in the housing channels and end caps.

ELECTRICAL:

High efficiency LED/Driver combination delivers 160 Lumens/Watt raw array efficacy with 80+ CRI. 4000K color temperature is standard with options for 2700K, 3000K, 3500K, and 5000K. 0-10V dimming comes standard with other control options available. THD <10% @ 120V, <15% @ 277V, PF> 0.95.

MOUNTING:

Surface, chain, or pendant options available for covered ceiling installations. Continuous row luminaires manufactured with aligning pins and utilize joiner bands. For further information, contact Sales Representative.

Splash and Food Zone: Surface for covered ceiling installations only.

TEMPERATURE CODE:

Class I, Div. 2 = T4A (120 °C); Class II, Div. 2 = T6 (85 °C)

(No luminaire surface exposed to the hazardous atmosphere will exceed this temperature. Based on 40 °C (104 °F) ambient.)

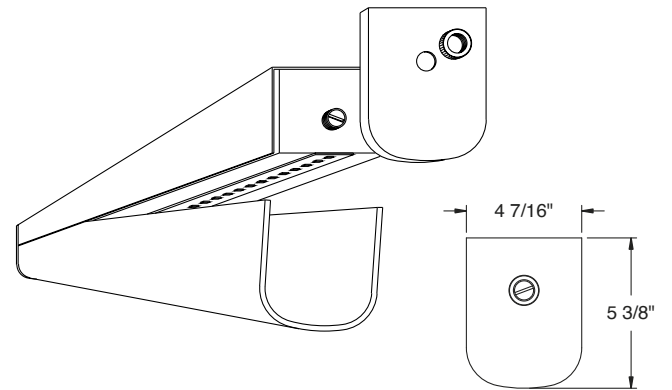

9/32" DIA. EMBOSSED MTG. HOLES (STD) OPTIONAL MTG STRAP W/ 5/16" DIA. MTG. HOLES 1/2" THREADED HUB W/ PLUG

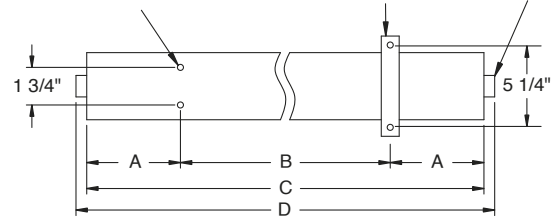

1/2" THREADED FLANGE (OPTIONAL, WET LOC.)

LENGTH (ft)	WEIGHT (lbs)	DIMENSIONS IN INCHES			
		A	B	C	D
1	5	2 3/32	10	14 3/16	15 5/16
2	10	4 19/32	16	25 3/16	26 5/16
3	15	10 1/8	16	36 1/4	37 3/8
4	19	7 5/8	32	47 1/4	48 3/8
5	24	13 1/8	32	58 1/4	59 3/8
6	29	10 5/8	48	69 1/4	70 3/8
7	24	8 5/32	64	80 5/16	81 7/16
8	39	13 21/32	64	91 5/16	92 7/16

FEATURES | OPTIONS

SQUARE POLYCARBONATE LENS AND END CAP

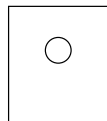
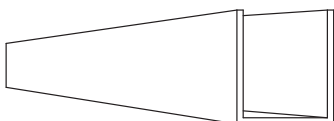

SQUARE LENS MODELS AVAILABLE
L9W = White Square Polycarbonate
L9P = Prismatic Square Polycarbonate

C3 JOINER BANDS

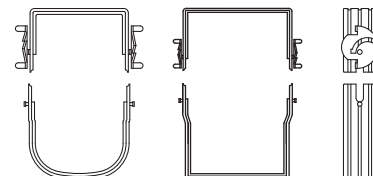

AG-TD-082124

Due to continuous development and improvements, specifications are subject to change without notice.

C3 Series – Wet & NSF Splash Zone Locations

PRODUCT ORDERING CODE

SERIES	LENGTH	MOUNTING	VOLTAGE	CCT	CRI	LUMENS	FINISH	LENS	DIMMING	OPTIONS
PMC3 Wet Location PMSC3 NSF Splash Zone ¹	1 1 FT 2 2 FT 3 3 FT 4 4 FT 5 5 FT 6 6 FT 7 7 FT 8 8 FT	MS1 Marine Straps Zinc MS2 Marine Straps Stainless CM Cable* Mount PM Pendant** Mount SF Surface Mount ³ Surface Mount with SC Bracket (for chain* mount or standoff)	UNV 120 - 277 VAC	27K 2700K ⁴ 3K 3000K 35K 3500K 4K 4000K 5K 5000K	CRI83 83 CRI CRI90 90 CRI	9L 900 lm (7W) 18L 1800 lm (14W) 27L 2700 lm (21W) 36L 3600 lm (27W) 45L 4500 lm (32W) 54L 5400 lm (39W) 63L 6300 lm (46W) 72L 7200 lm (53W)	PZ White Painted Zinc Steel S4 Stainless Steel ³	L3 0.125 White Acrylic (Cell Cast) LH3 0.150 Extra Heavy White Acrylic L4 0.140 50% DR Ext. Prismatic Acrylic (P20) L5 0.125 StarFrost® Acrylic (base) L7 0.125 White Polycarbonate L8 0.156 Prismatic Polycarbonate (P12) L9W White Square Polycarbonate L9P Prismatic Square Polycarbonate	LD Dimming 0-10V	BBU 10W Battery Backup, Integral ¹⁰ BBU1 12W Battery Backup, Integral ¹⁰ BBUR2 20W Battery Backup, Remote ⁶ F1 GLR/HLR Fusing (Fast) F2 GMF/HLR Fusing (Slow) M3C In-Row Center ⁷ M3E In-Row End ⁷ J8 Wire Guard ⁸ P11 Guardcraft® Antimicrobial Coating ⁹ T3 Tamper Resistant (Hex w/pin or other) ³ T6 Screw-on End Caps (Requires W5) T7 Hub Cap (Replaces Ring & Plug) W5 Rear Wire Entry ⁵
		*Requires third-party hardware **Requires third-party mounting stem and hardware				Selection must match the selected length	Lumens (Nominal)			

Footnotes:

- ¹ NSF Splash Zone luminaires (PMS prefix) may become soiled, but are outside the danger of recontamination
- ³ Required for 3G rating
- ⁴ Only 90 CRI
- ⁵ Consult Factory
- ⁶ The 20W Battery Backup Remote powers a minimum of 3 luminaires and must be mounted on the outside of the luminaire or in a remote dry/damp location
- ⁷ Refer to In-Row Construction drawing below to determine necessary center & end units. Every In-Row luminaire must include two ends (M3E), one or more centers (M3C) and joiner bands (drawing details pg. 1)
- ⁸ Is not available for NSF Splash and Food Zones
- ⁹ Only available with White Painted Zinc Steel Finish
- ¹⁰ Only available on lengths 4 FT and up

C3 Series – NSF Food Zone Location

PRODUCT ORDERING CODE

SERIES	LENGTH	MOUNTING	VOLTAGE	CCT	CRI	LUMENS	FINISH	LENS	DIMMING	OPTIONS
PMFC3		SF	UNV				S4		LD	
PMFC3 NSF Food Zone ²			UNV 120 - 277 VAC		CRI83 83 CRI CRI90 90 CRI		S4 Stainless Steel ³		LD Dimming 0-10V	
	1 1 FT 2 2 FT 3 3 FT 4 4 FT 5 5 FT 6 6 FT 7 7 FT 8 8 FT	SF Surface Mount ³		27K 2700K ⁴ 3K 3000K 35K 3500K 4K 4000K 5K 5000K				L4 0.140 50% DR Extruded Prismatic Acrylic (P20) L5 0.125 StarFrost [®] Acrylic (base)		
						1 FT 9L 900 lm (7W) 2 FT 18L 1800 lm (14W) 3 FT 27L 2700 lm (21W) 4 FT 36L 3600 lm (27W) 5 FT 45L 4500 lm (32W) 6 FT 54L 5400 lm (39W) 7 FT 63L 6300 lm (46W) 8 FT 72L 7200 lm (53W)		BBU 10W Battery Backup, Integral ¹⁰ BBU1 12W Battery Backup, Integral ¹⁰ BBUR2 20W Battery Backup Remote ⁶ F1 GLR/HLR Fusing (Fast) F2 GMF/HLR Fusing (Slow) T7 Hub Cap (Replaces Ring & Plug) W5 Rear Wire Entry ⁵		
						Selection must match the selected length	Lumens (Nominal)			

Footnotes:

- ² NSF Food Zone luminaires (PMF prefix) come in DIRECT CONTACT with food
- ³ Required for 3G rating
- ⁴ Only 90 CRI
- ⁵ Consult Factory
- ⁶ The 20W Battery Backup Remote powers a minimum of 3 luminaires and must be mounted on the outside of the luminaire or in a remote dry/damp location
- ¹⁰ Only available on lengths 4 FT and up

C3 Series – Hazardous Location

PRODUCT ORDERING CODE

SERIES	LENGTH	MOUNTING	VOLTAGE	CCT	CRI	LUMENS	FINISH	LENS	DIMMING	OPTIONS
PMHC3			UNV						LD	
PMHC3 Hazardous			UNV 120 - 277 VAC		CRI83 83 CRI CRI90 90 CRI		PZ White Painted Zinc Steel S4 Stainless Steel ³		LD Dimming 0-10V	
	1 1 FT 2 2 FT 3 3 FT 4 4 FT 5 5 FT 6 6 FT 7 7 FT 8 8 FT			27K 2700K ⁴ 3K 3000K 35K 3500K 4K 4000K 5K 5000K				L3 0.125 White Acrylic (Cell Cast) LH3 0.150 Extra Heavy White Acrylic L4 0.140 50% DR Ext. Prismatic Acrylic (P20) L5 0.125 StarFrost® Acrylic (base) L7 0.125 White Polycarbonate L8 0.156 Prismatic Polycarbonate (P12) L9W White Square Polycarbonate L9P Prismatic Square Polycarbonate		
		SF Surface Mount ³ Surface Mount with SC Bracket (for chain* mount or standoff) PM Pendant** Mount *Requires third-party hardware **Requires third-party mounting stem and hardware and S4 Option								
						1 FT 9L 900 lm (7W) 2 FT 18L 1800 lm (14W) 3 FT 27L 2700 lm (21W) 4 FT 36L 3600 lm (27W) 5 FT 45L 4500 lm (32W) 6 FT 54L 5400 lm (39W) 7 FT 63L 6300 lm (46W) 8 FT 72L 7200 lm (53W)				F1 GLR/HLR Fusing (Fast) F2 GMF/HLR Fusing (Slow) M3C In-Row Center ⁷ M3E In-Row End ⁷ J8 Wire Guard ⁸ P11 Guardcraft® Antimicrobial Coating ⁹ T3 Tamper Resistant (Hex w/pin or other) ³ T6 Screw-on End Caps (Requires W5) T7 Hub Cap (Replaces Ring & Plug) W5 Rear Wire Entry*** ⁵
						Selection must match the selected length	Lumens (Nominal)			*** Requires S4 Option (Battery Backup NOT Available for Hazardous Location)

Footnotes:
³ Required for 3G rating
⁴ Only 90 CRI
⁵ Consult Factory
⁷ Refer to In-Row Construction drawing below to determine necessary center & end units. Every In-Row luminaire must include two ends (M3E), one or more centers (M3C) and joiner bands (drawing details pg. 1)
⁸ Is not available for NSF Splash and Food Zones
⁹ Only Available with White Painted Zinc Steel Finish

IN-ROW CONSTRUCTION

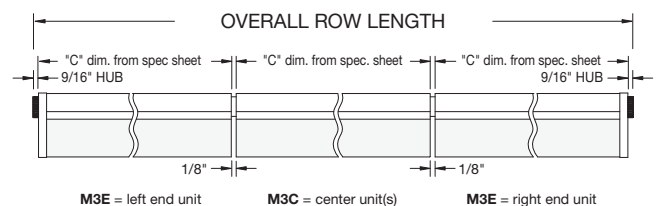

LUMEN OUTPUT: All listed lumen values are nominal. Lens transmission and fixture efficiency affect overall lumens.

INDIVIDUAL UNITS STANDARD
NOT ALL COMBINATIONS POSSIBLE